

MODEL 446

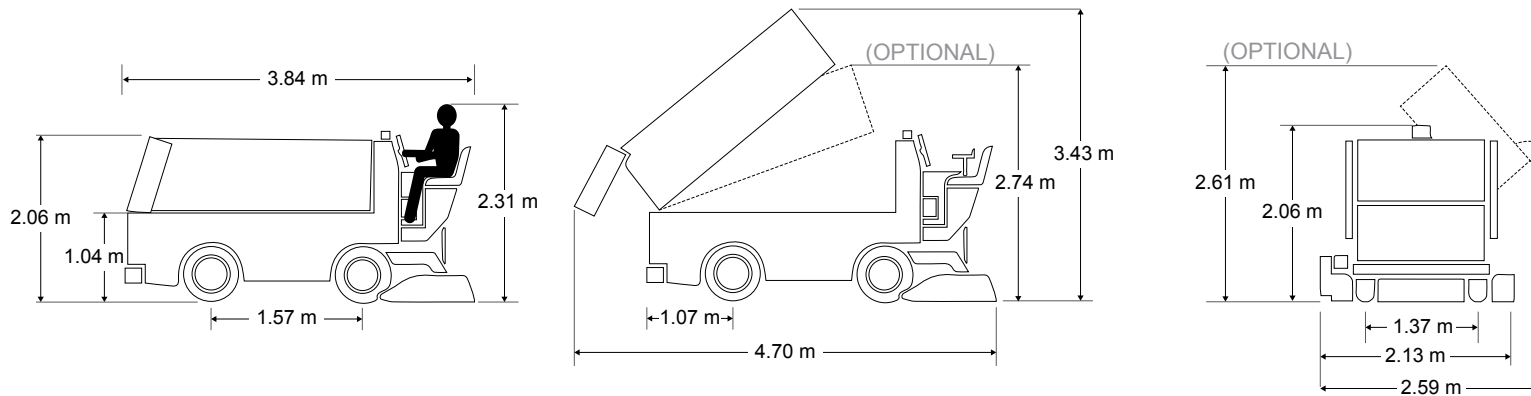

CAPACITIES

Snow Tank

Actual Volume	2.66 m ³	94 cu. ft.
Compacted	3.17 m ³	122 cu. ft.

Water

Ice Making	627 L	166 gal.
Wash Water	218 L	58 gal.
Total	845 L	224 gal.

Hydraulic Oil	72 L	19 gal.
----------------------	------	---------

POWERTRAIN

Four-Wheel Drive	
Engine	Mitsubishi® 2.4 L / 59 HP at 2500 RPM Four Cylinder Liquid Cooled
Transmission	Continuously variable hydrostatic pump and motor are axial-piston type.
Hydraulics	Powerful single pump for the vertical and horizontal augers. Hydraulic down pressure for optimal resurfacing results.

Axles

Front	1950 kg	4300 lb
Rear	2177 kg	6400 lb

Brakes	Full Hydrodynamic Braking
---------------	---------------------------

DIMENSIONS

Overall

	L	W	H	L	W	H
Snow Tank Down	3.84 m	2.13 m	2.06 m	151 in.	84 in.	81 in.
Snow Tank Up	4.70 m	2.13 m	3.43 m	185 in.	84 in.	135 in.

Shaving Blade

	L	W	H	L	W	H
	195.6 cm	12.7 cm	1.27 cm	77 in.	5 in.	0.5 in.

Clearance

Minimum Operator Height Clearance	2.31 m	91 in.
Snow Pit Clearance	104.1 cm	41 in.

Conveyor System

Horizontal Auger Diameter	25.4 cm	10 in.
Vertical Auger Diameter	25.4 cm	10 in.

Manueverability

Wheelbase	1.57 m	62 in.
Wheel Track	1.37 m	54 in.
Turning Radius at Conditioner	4.57 m	15 ft.

Weight

Empty	2660 kg	5860 lb
with Water	3502 kg	7720 lb